

---

# SPECIFICATION FOR APPROVAL

Product	MAGNETIC BUZZER
Part No.	AC-701S-P1
Customer Approval	

Approved By	Checked By	Made By



**A & B Components**

**<http://www.speaker-tw.com>**

# 1. Specifications

AC-701S-P1

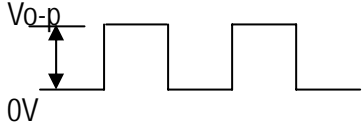
Items		Units	Specifications	Conditions
01	Rated Voltage	Vo-p	1.5	
02	Operating Voltage	Vo-p	1 ~ 3	
03	Consumption Current	mA (Max)	Mean 80	Applying rated voltage, rated frequency Square wave, 1/2 duty subject to standard state.
			Peak 240	
04	Direct Current Resistance	Ohm	6±1	
05	Sound Output	dBA (min)	70	Distance at 10cm, applying rated voltage, rated frequency square wave, 1/2 duty subject to standard state.
06	Rated Frequency	Hz	3000	
07	Operating Temp.	°C	-30 ~ +75	
08	Storage Temp.	°C	-40 ~ +85	
09	Weight	Gram	1.0	

## 2. Measuring Method

### 2-1. Test Condition

STANDARD

Temperature : 15 ~ 35°C

Relative humidity : 25% ~ 85%,

Atmospheric pressure : 860mbar to 1060mbar.

JUDGEMENT

Temperature : 20±3°C

Relative humidity : 60% ~ 70%,

Atmospheric pressure : 860mbar to 1060mbar

### 2-2. Standard Drive Circuit:

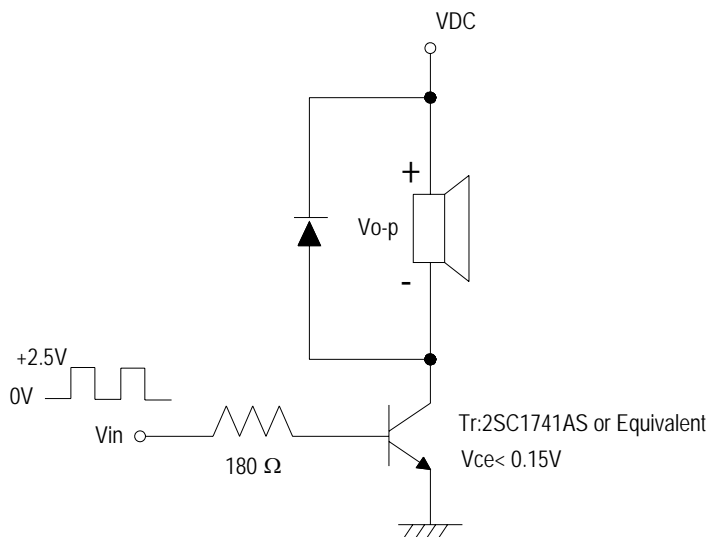

## 2-3. Standard Test Fixture

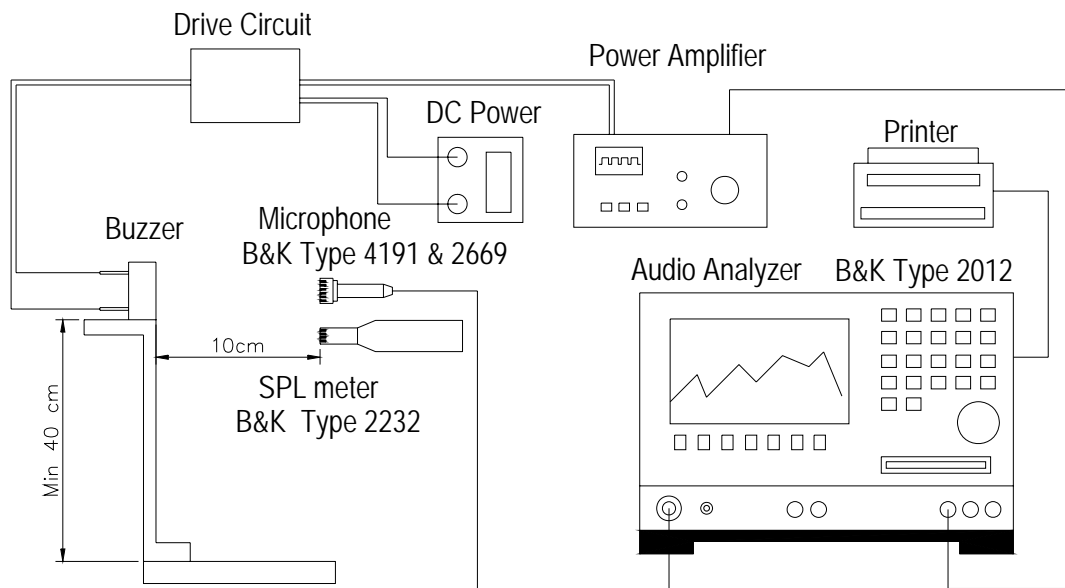

## 2-4. Frequency Response Curve

AC-701S-P1

X:2.9854kHz

Y:72.16dB

ZA:Live Curve

SSR T. RMS

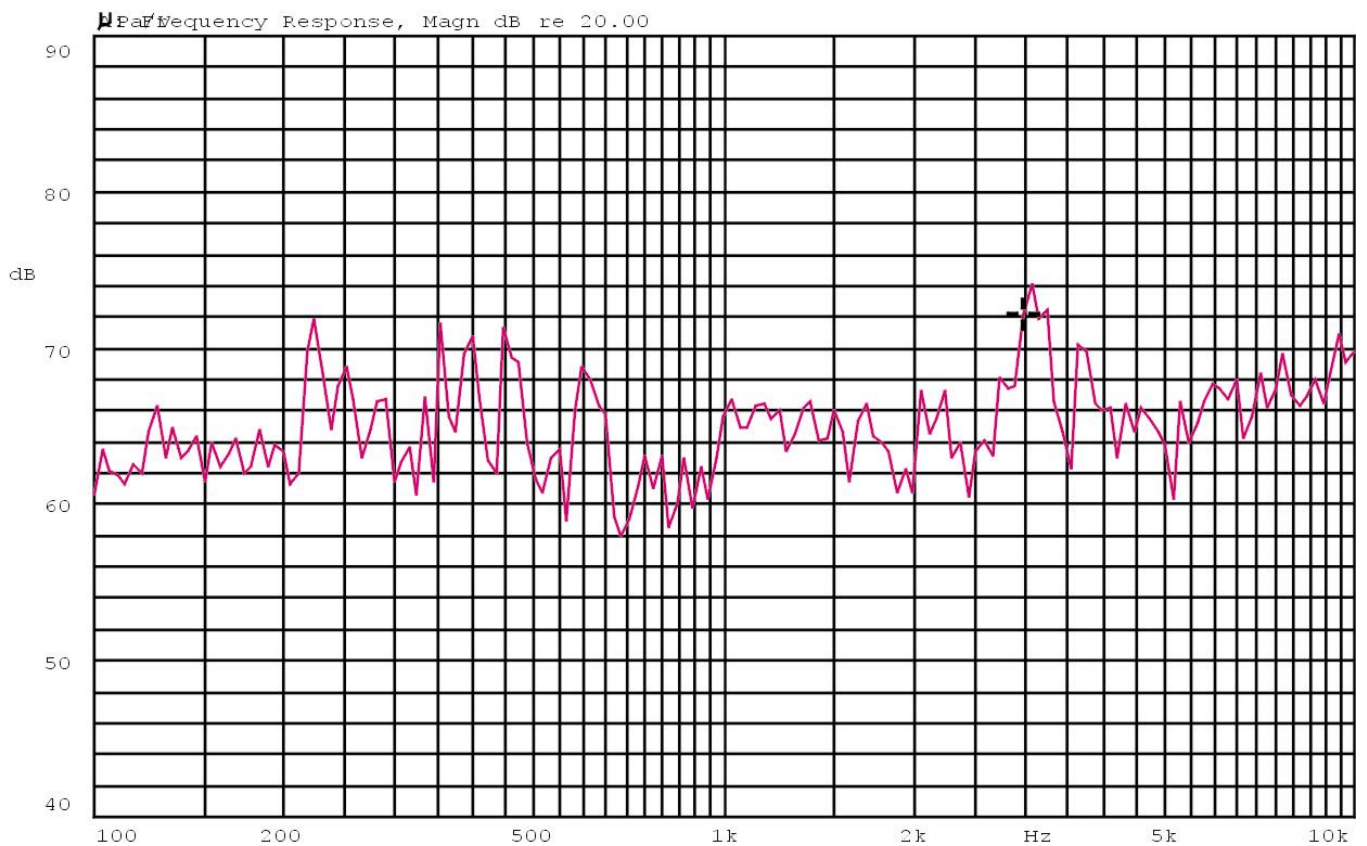

Mode: SSR

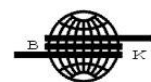

REV NO.	REVISION NOTE	APPROVAL	DATE
---------	---------------	----------	------

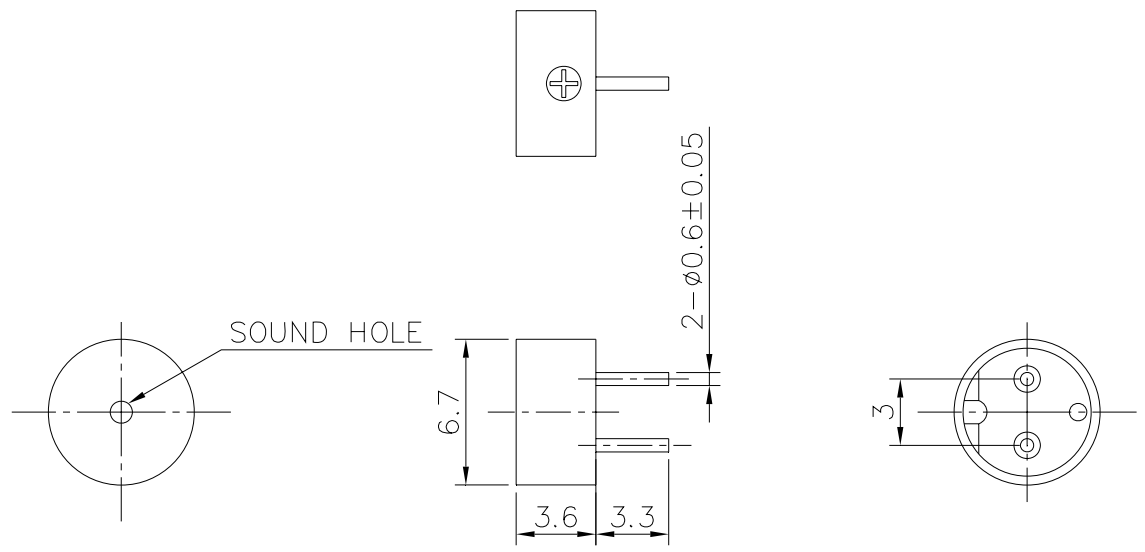

*Wave Solder and Wash Allowed.*

TITLE: <i>SOUND TRANSDUCER</i>		DRAWN: <i>Richard</i> 10/12/2004	SCALE: 3:1	SHEET: 1 of 1
PART NO. <i>AC-701S-P1</i>	1	DESIGNED: <i>R&amp;D DEP.</i>	UNITS: <i>mm</i>	
DWG NO. <i>DTE-2060</i>		CHECKED:	TOLERANCE $\pm 0.2$	
	REV	APPROVAL:	UNLESS OTHERWISE SPECIFIED:	
		MATERIAL: <i>PPO</i>	ONE PLACE DECIMAL $\pm$ ***	
			TWO PLACE DECIMAL $\pm$ ***	
			THREE PLACE DECIMAL $\pm$ ***	

*A & B Components*

## 4. RELIABILITY TEST

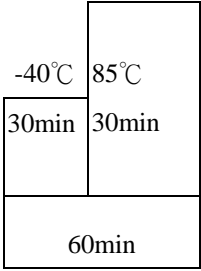
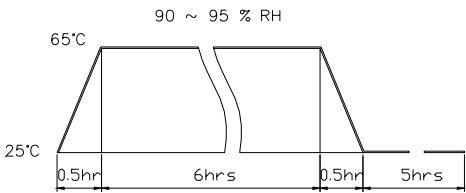
Item	Test conditions	Evaluation standard
01 High temp.Storage life	The part shall be capable of withstanding a storage Temperature of 85°C for 96 hours.	After the test the part shall meet specifications without Any degradation in appearance and performance except S.P.L S.P.L shall be 74dB or more.
02 Low temp.Storage life	The part shall be capable of withstanding a storage Temperature of -40°C for 96 hours.	
03 Temp. cycle	The part shall be subjected 10 cycles. One cycle shall consist of; <div style="text-align: center; margin: 10px 0;">  </div>	
04 Temp./Humidity cycle	The part shall be subjected 10 cycles. One cycle shall be 12 hours and consist of; <div style="text-align: center; margin: 10px 0;">  </div>	
05 Operating life	Rated Voltage,Frequency applied. 1. Ordinary temperature The part shall be subjected to 1000 hours at room temperature (25 ±10°C) 1. High temperature The part shall be subjected to 500 hours at 75°C 2. Low temperature The part shall be subjected to 500 hours at -30°C	
06 Vibration	The part shall be subjected to a vibration cycle of 10Hz to 55Hz to 10Hz in a period of 1 minute. Total peak amplitude shall be 1.52mm (9.3G). The vibration test shall consist of 2 hours per plane in each three mutually perpendicular planes for a total time of 6 hours.	

Item		Test conditions	Evaluation standard
07	Fixed drop	The part shall be mounted on standard pc board and dropped from a height of 152cm onto a concrete floor 5 times in each 6 planes.(a total of 30 times)	<p>After the test the part shall meet specifications without Any degradation in appearance and performance except S.P.L</p> <p>S.P.L shall be 74dB or more.</p>
08	Free drop	The part only shall be dropped from a height of 75cm onto a 40mm thick wooden board 3 times in 3 axes (X.Y.Z). (a total of 9 times).	
09	Solder heat resistance	Soldering into solderbath : $350\pm 5^{\circ}\text{C}$ Soaking time : $3.5\pm 0.5$ sec	
10	Solder ability	Soldering : $250\pm 5^{\circ}\text{C}$ / 5 Sec. $350\pm 5^{\circ}\text{C}$ / 1.5 Sec Soldering t into solderbath : $250\pm 5^{\circ}\text{C}$ Soaking time : $2\pm 0.5$ sec	
11	Lead strength	Pull lead with a force of 10N,on the direction of the lead axis for 10 : $10\pm 1$ sec	
12	Washability	Solvent : deionized water Solvent temp. : $55\pm 5^{\circ}\text{C}$ Soaking time : $5\pm 0.5$ min.	