SPECIFICATION FOR APPROVAL

Product	MAGNETIC BUZZER
Part No.	AS-501A
Customer Approval	

Approved By	Checked By	Made By



A & B Components

<http://www.speaker-tw.com>

1. Specifications

AS-501A

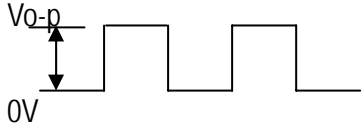
Items		Units	Specifications	Conditions
01	Rated Voltage	Vo-p	1.5	
02	Operating Voltage	Vo-p	1.0 ~ 2.0	
03	Consumption Current	mA (Max)	Mean 35	Applying rated voltage, rated frequency Square wave, 1/2 duty subject to standard state.
			Peak 105	
04	Direct Current Resistance	Ohm	16±2.4	
05	Sound Output	dBA (min)	78	Applying rated voltage, rated frequency square wave, 1/2duty, standard state. Distance at 10cm,
06	Rated Frequency	Hz	2048	
07	Operating Temp.	°C	-30 ~ +75	
08	Storage Temp.	°C	-40 ~ +85	
09	Weight	Gram	2.0	

2. Measuring Method

2-1. Test Condition

STANDARD

Temperature : 15 ~ 35°C

Relative humidity : 25% ~ 85%,

Atmospheric pressure : 860mbar to 1060mbar.

JUDGEMENT

Temperature : 20±3°C

Relative humidity : 60% ~ 70%,

Atmospheric pressure : 860mbar to 1060mbar

2-2. Standard Drive Circuit:

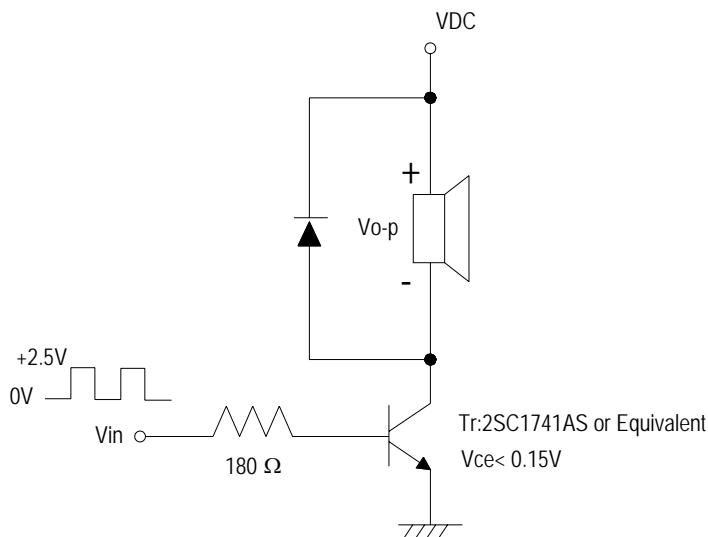

2-3. Standard Test Fixture

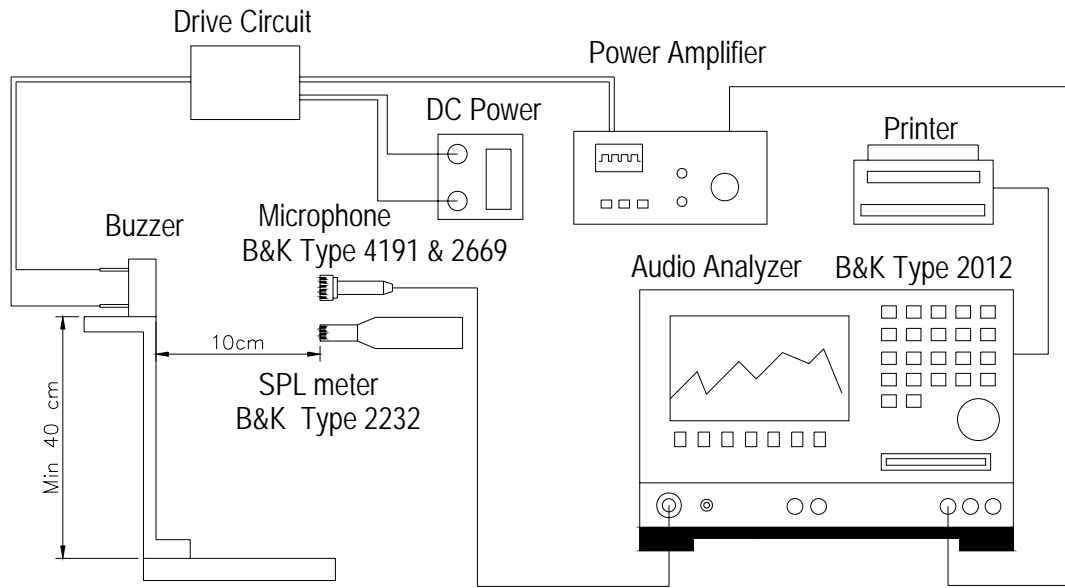

2-4. Frequency Response Curve

X:2.0535kHz Y:86.20dB ZA:Live Curve SSR T. RMS

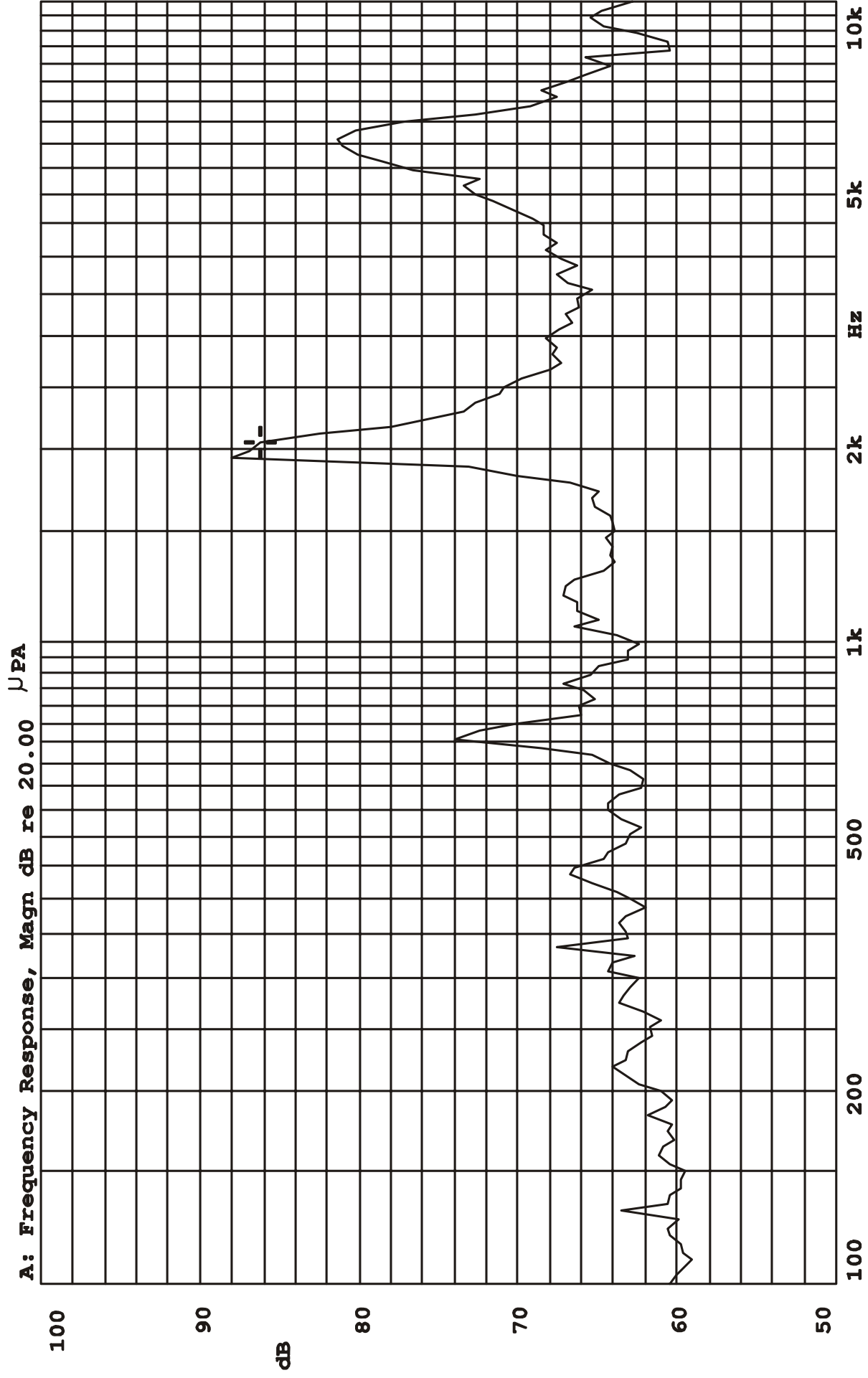

Mode: SSR

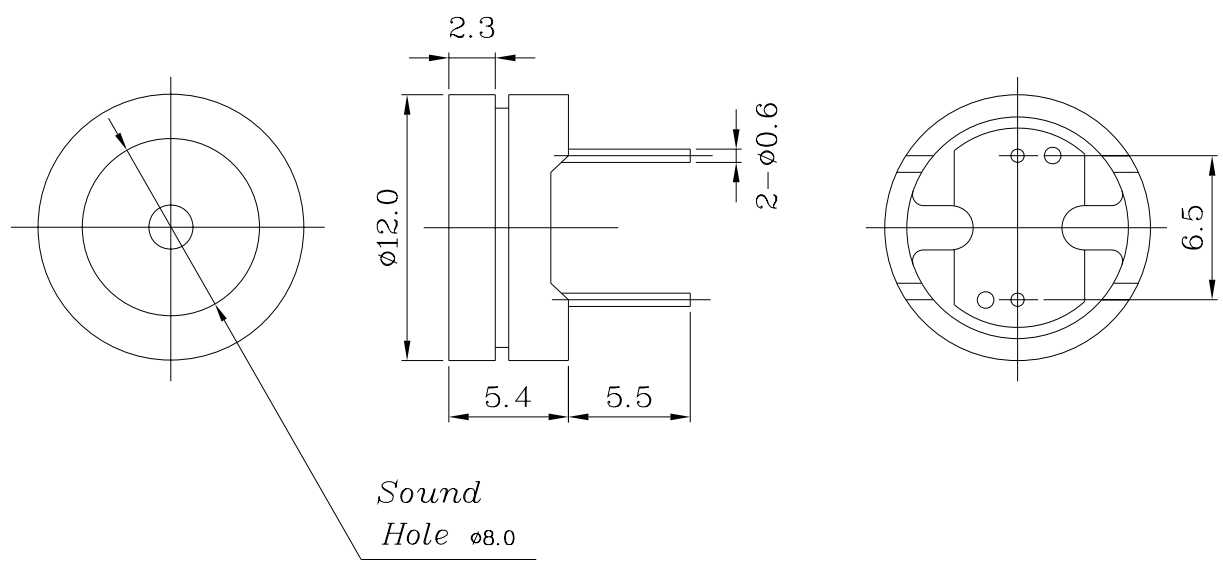

TITLE: SOUND TRANSDUCER DIMENSIONS		DRAWN: <i>Richard</i> 2003/07/30	SCALE: 3/1	SHEET: 1 OF 1
PART NO. AS-501A	1	DESIGNED: R&D DEP.	UNITS: mm	
DWG NO. DTE-1053		CHECKED:	TOLERANCE ± 0.5	
	REV	APPROVAL:	UNLESS OTHERWISE SPECIFIED:	
		MATERIAL: PPO	ONE PLACE DECIMAL ± ***	
			TWO PLACE DECIMAL ± ***	
			THREE PLACE DECIMAL ± ***	

A & B Components

4. RELIABILITY TEST

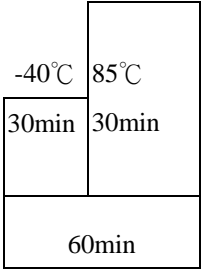
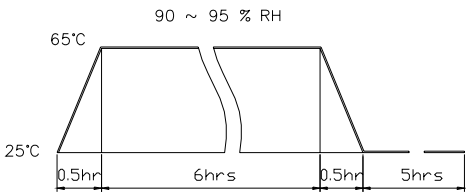
Item	Test conditions	Evaluation standard
01 High temp.Storage life	The part shall be capable of withstanding a storage Temperature of 85°C for 96 hours.	After the test the part shall meet specifications without Any degradation in appearance and performance except S.P.L S.P.L shall be 74dB or more.
02 Low temp.Storage life	The part shall be capable of withstanding a storage Temperature of -40°C for 96 hours.	
03 Temp. cycle	The part shall be subjected 10 cycles. One cycle shall consist of; <div style="text-align: center; margin: 10px 0;">  <pre> graph TD A[30min] --- B[30min] B --- C[60min] A --- C style A fill:#fff,stroke:#000 style B fill:#fff,stroke:#000 style C fill:#fff,stroke:#000 </pre> </div>	
04 Temp./Humidity cycle	The part shall be subjected 10 cycles. One cycle shall be 12 hours and consist of; <div style="text-align: center; margin: 10px 0;">  <pre> graph TD A[0.5hr] --- B[6hrs] B --- C[0.5hr] C --- D[5hrs] A --- D style A fill:#fff,stroke:#000 style B fill:#fff,stroke:#000 style C fill:#fff,stroke:#000 style D fill:#fff,stroke:#000 </pre> </div>	
05 Operating life	Rated Voltage,Frequency applied. 1. Ordinary temperature The part shall be subjected to 1000 hours at room temperature (25 ±10°C) 1. High temperature The part shall be subjected to 500 hours at 75°C 2. Low temperature The part shall be subjected to 500 hours at -30°C	
06 Lead Strength	Pull load on the direction of the lead axis for 10 ±1 sec.	
07 Vibration	The part shall be subjected to a vibration cycle of 10Hz to 55Hz to 10Hz in a period of 1 minute. Total peak amplitude shall be 1.52mm (9.3G). The vibration test shall consist of 2 hours per plane in each three mutually perpendicular planes for a total time of 6 hours.	

Item		Test conditions	Evaluation standard
08	Fixed drop	The part shall be mounted on standard pc board and dropped from a height of 152cm onto a concrete floor 5 times in each 6 planes.(a total of 30 times)	<p>After the test the part shall meet specifications without Any degradation in appearance and performance except S.P.L</p> <p>S.P.L shall be 74dB or more.</p>
09	Free drop	The part only shall be dropped from a height of 75cm onto a 40mm thick wooden board 3 times in 3 axes (X.Y.Z). (a total of 9 times).	
10	Solder heat resistance	Soldering into solderbath : $350\pm 5^{\circ}\text{C}$ Soaking time : 3.5 ± 0.5 sec	
11	Solder ability	Soldering : $250\pm 5^{\circ}\text{C}$ / 5 Sec. $350\pm 5^{\circ}\text{C}$ / 1.5 Sec Wave Solder NOT Allowed!	
12	Lead strength	Pull lead with a force of 10N, on the direction of the lead axis for 10 : 10 ± 1 sec	
13	Washability	Solvent : deionized water Solvent temp. : $55\pm 5^{\circ}\text{C}$ Soaking time : 5 ± 0.5 min.	