

---

# SPECIFICATION FOR APPROVAL

Product	PIEZO BUZZER (SMD)
Part No.	APD-1405-KX2
Customer Approval	

Approved By	Checked By	Made By



**A & B Components**

**<http://www.speaker-tw.com>**

# APD-1405-KX2

## Scope

This specification relates to piezoelectric sounder intended to be used in alarm systems, etc. Please contact us before using any of the products the applications not described above

Items		Units	Specifications	Conditions
01	Rated Voltage	Vp-p	5.0	Square Wave
02	Operating Voltage	Vp-p	1.0~30	Square Wave
03	Consumption Current	mA(max)	3	.Rated Voltage, Distance at 10 cm free air 4000Hz, Square Wave
04	Sound Pressure Label	dB(min)	75	
05	Resonant Frequency	Hz	4000±300	
06	Static Capacitance	nF	10.0±30%	At 1KHz
07	Operating Temp.	°C	-20 ~ +70	
08	Storage Temp.	°C	-30 ~ +80	
09	Dimension	mm	14.6 x 14 x 4.3	See attached drawing.

### Standard condition:

Ordinary Temp.(+5~+35°C), Humidity(45~85%RH), Air Pressure(860~1060Hpa)

In case of doubtful judgment, the test is re-performed under basic state.

### Basic State:

Temp.(+25±3°C), Humidity(60~70%RH),Air Pressure(860~1060Hpa).

### Soldering Heat Resistance (Re-Flow)

Following profile of heat stress is applied to sounder, then being place in natural condition for 1 hour, sounder shall be measured.

Pre-heating conditions shall be +140°C to 160°C for 60 to 120 seconds. Ascending time up to +150°C shall be longer than 30 second.

Heating conditions shall be within 10 seconds at +220°C min., but peak temperature shall be lower than+230°C

# STANDARD TEST FIXTURE

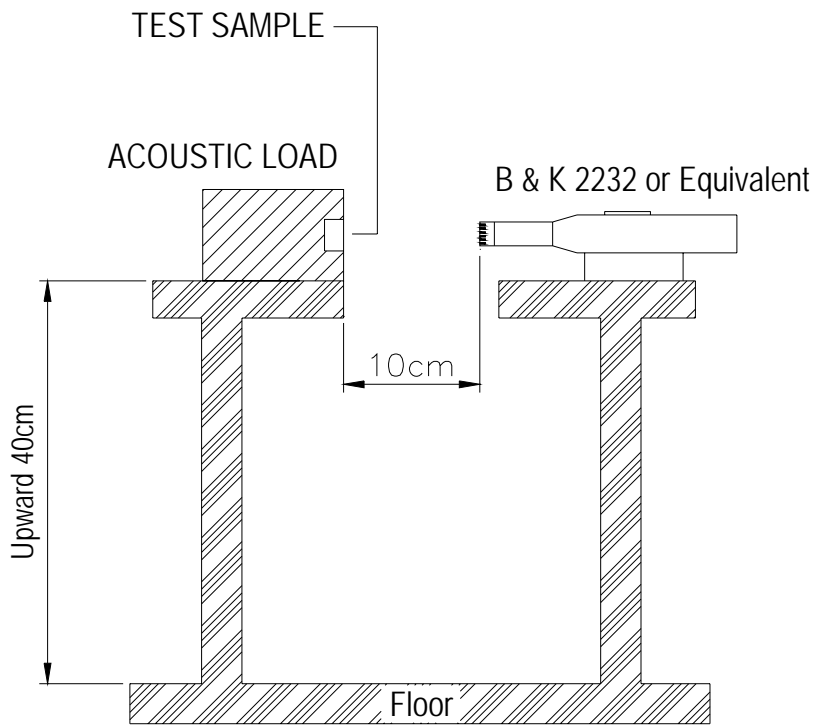

# Standard test condition of piezo buzzer

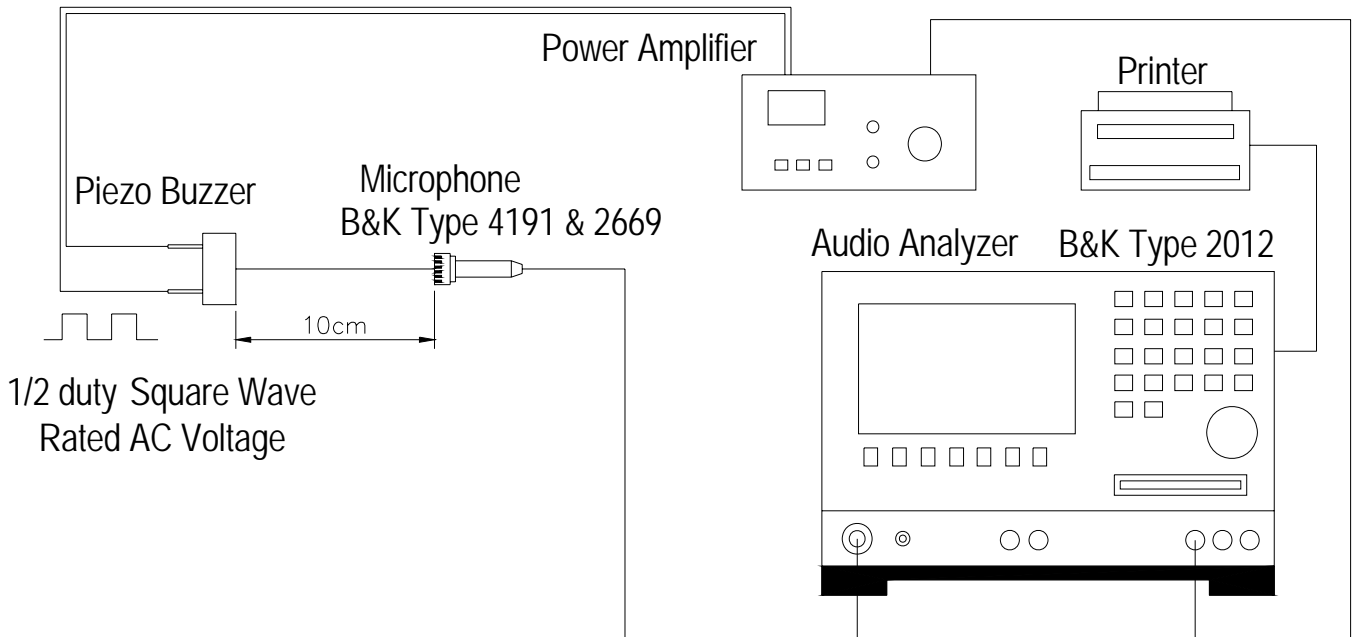

X:3.9811kHz

Y:81.91dB

ZA:Live Curve

SSR T. RMS

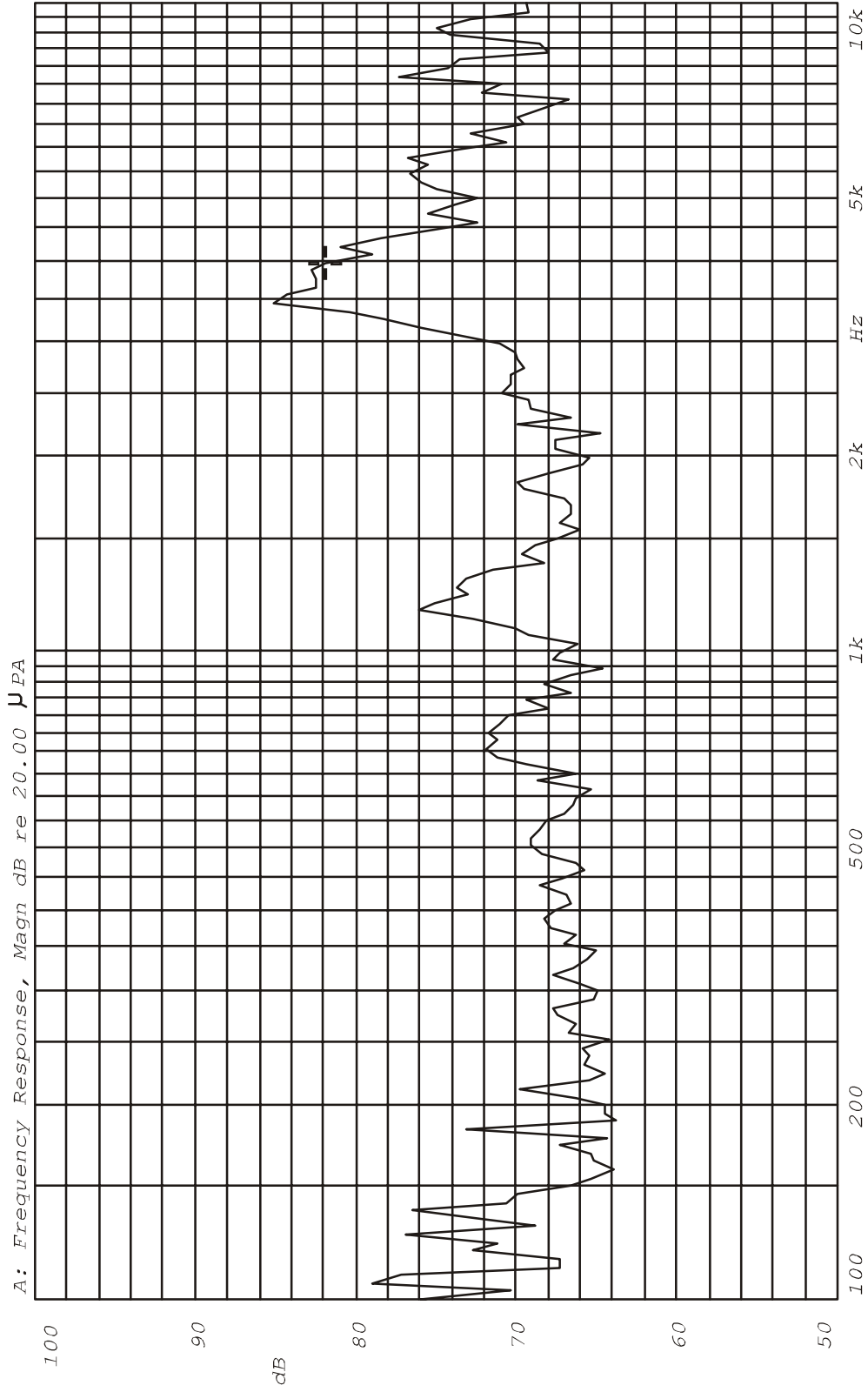

Mode: SSR

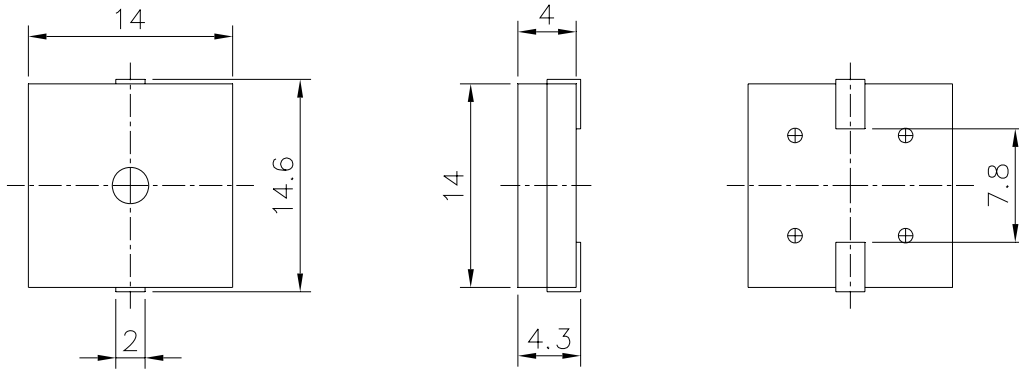

TITLE: <i>PIEZO BUZZER (SMD)</i>		DRAWN: <i>Richard</i> 01/22/2002	SCALE: 2:1	SHEET: 1 OF 1
PART NO. <i>APD-1405-KX2</i>		DESIGNED: <i>R&amp;D DEP.</i>	UNITS: <i>mm</i>	
DWG NO. <i>DPD-1001</i>		1	TOLERANCE $\pm 0.2$	
		REV	UNLESS OTHERWISE SPECIFIED:	
		MATERIAL: <i>PPS</i>	ONE PLACE DECIMAL $\pm$ ***	
			TWO PLACE DECIMAL $\pm$ ***	
			THREE PLACE DECIMAL $\pm$ ***	

*A & B Components*

REV NO.	REVISION NOTE	APPROVAL	DATE
---------	---------------	----------	------

RECOMMENDED SOLDERING POINTS PATTERN

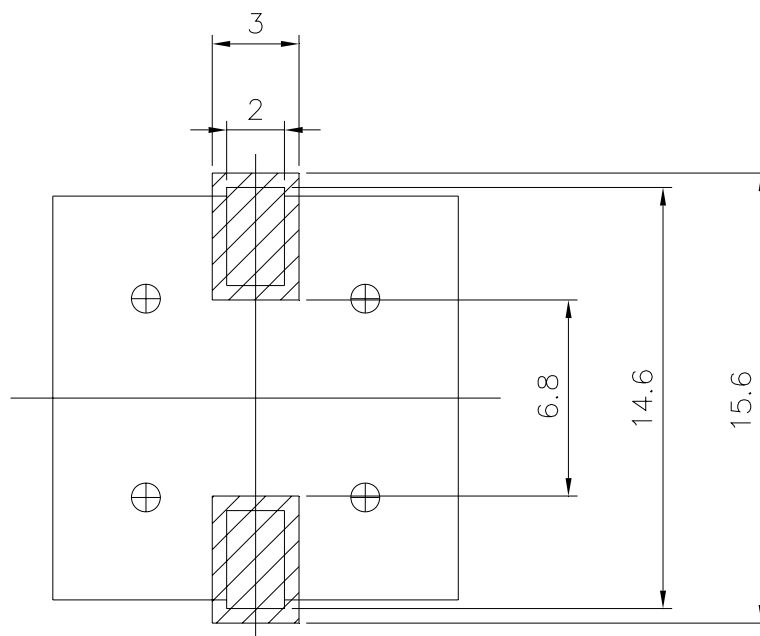

TITLE: RECOMMENDED LAND PATTERN DIMENSIONS		DRAWN: <i>Richard</i> 01/22/2002	SCALE: 4:1	SHEET: 1 OF 1
PART NO. APD-1405-KX2-1	1	DESIGNED: R&D DEP.	UNITS: mm	
DWG NO. DPD-1001-1		CHECKED:	TOLERANCE ± 0.2	
	REV	APPROVAL:	UNLESS OTHERWISE SPECIFIED:	
		MATERIAL: PPS	ONE PLACE DECIMAL ± ***	
			TWO PLACE DECIMAL ± ***	
			THREE PLACE DECIMAL ± ***	

*A & B Components*

# RELIABILITY TEST

## APD-1405-KX2

Item		Test conditions	Evaluation standard
1	High temp storage life	The part shall be capable of withstanding the storage temperature of +80°C for 240 hours.	<p>After the test, the part shall meet specifications without any degradation in appearance and performance except SPL. SPL shall be 67dB or more</p>
2	Low temp storage life	The part shall be capable of withstanding the storage temperature of -30°C for 240 hours.	
3	Temp. cycle	After being placed in chamber at -30±2°C for 30 minutes, products shall be placed at room temperature +20°C. After 15 minutes at this temperature, products shall be placed in a chamber at +85±2°C. After 30 minutes at this temperature, products shall be return to room temperature +20°C for 15 minutes. After 5 above cycles, products shall be measured after being placed in natural condition for 4 hours.	
4	Humidity cycle	After being placed in a chamber with 90-95% R.H. at 40±2°C for 24 hours and then being placed in natural condition for 4 hours.	
5	Operating life	Driving the sounder at 25±10°C for 240hrs. Input 5.0VP-P square wave 4000Hz	
6	High temp.	The part shall be subjected to 240 hours at +75°C with 5.0VP-P,4000Hz applied.	
7	Low temp.	The part shall be subjected to 240 hours at -20°C with 5.0VP-P,4000Hz applied.	
8	Vibration	10~55Hz 1.5mm 55~150Hz 5G 10~200~10Hz 15minutes X,Y,Z,3directions 2h/direction.	
9	Fixed drop	The part mounted on an exclusive fixture(115g) shall be dropped 5 times from a height of 152cm onto concrete in each of 6 different axes(total 6 times)	
10	Free drop	The part shall be dropped freely from a height of 100cm onto concrete 1 time in 6 axes.(total 6 time)	
11	Solder ability	The part leads shall be immersed in molten solder maintained at 235±5°C for a period of 2.0±0.5 seconds	Ninety-five percent(95%) coverage with a continuous coating of bright new solder
12	Strength of Terminal	It shall be more than 10N in the vertical direction of terminal in the state that 4 terminals are soldered on PCB	Same as items of No. 1 to No. 10

# Package

Item \ package	Small box	Internal box	External case
Size	$\phi$ 33.0 x 2.6	34 x 34 x 8	42.0x 36.5 x 37
Material	polystyrene	paper bag	paper board
Quantity	600 pcs	1200 pcs/bag	6000 pcs/case
G. Weight	850 g	2.0Kg	11.2Kg

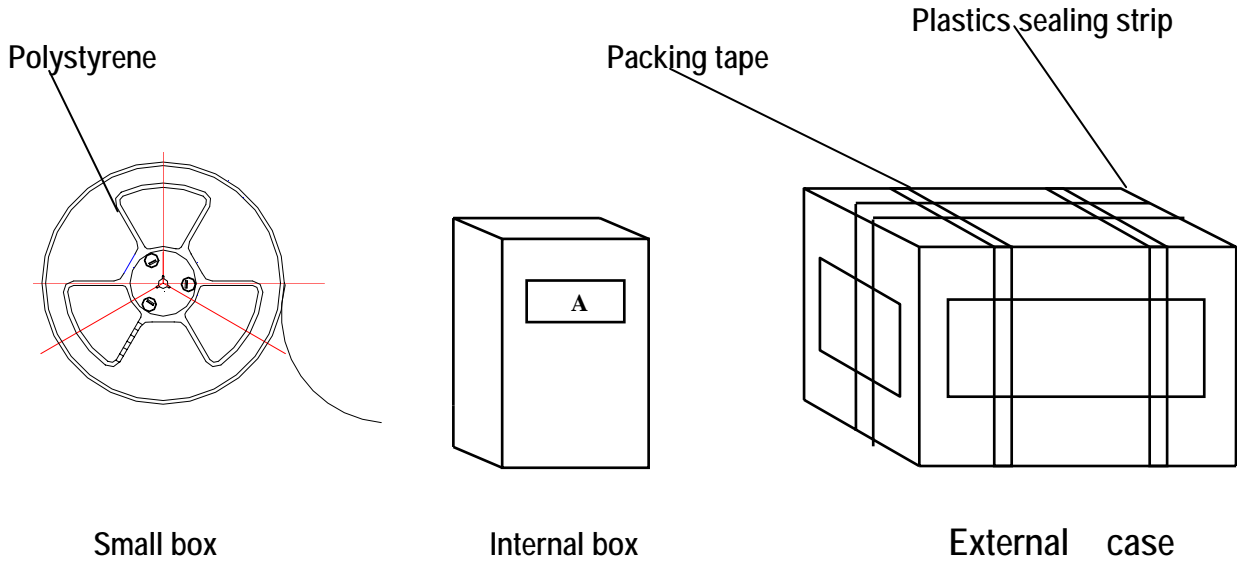
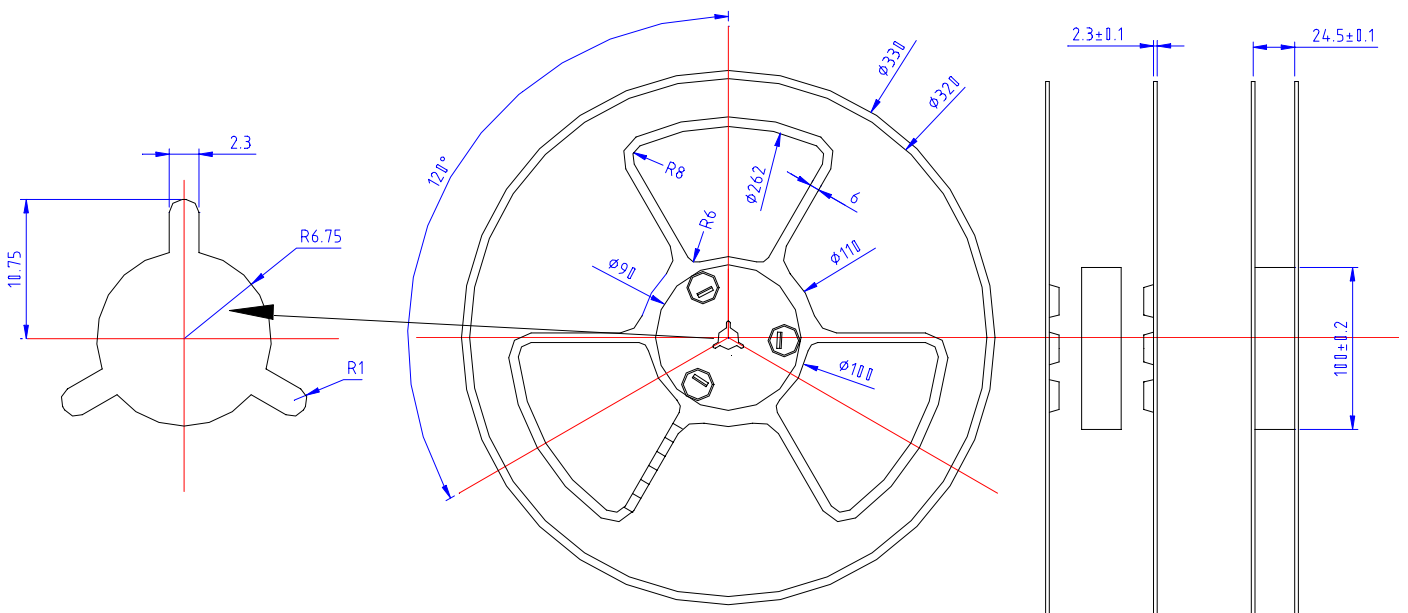

Fig.A





Small box is composed packing tape and reel, packing tape see Fig.A, packing reel see Fig.A  
 Fig,B

