SPECIFICATION FOR APPROVAL

Product	PIEZO BUZZER ELEMENT
Part No.	AE-3529E-C1
Customer Approval	

Approved By	Checked By	Made By



A & B Components

<http://www.speaker-tw.com>

AE-3529E-C1

ITEM	CONDITION
01 Type.	EXTERNAL -drive type sound element
02 Resonant Frequency (KHz)	2.9 ± 0.5 at $25 \pm 2^\circ\text{C}$, 45~60% RH
03 Resonant Impedance (OHM)	350 OHM Max. at $25 \pm 2^\circ\text{C}$, 45~60% RH
04 Capacity (PF)	$30000 \pm 30\%$ at 1.0KHz 1Vrms
05 Plate Material	BRASS
06 Lead Wire Spec.	Awg 28, UL 1095
07 Operating Temperature ($^\circ\text{C}$)	-20 to +60
08 Storage Temperature ($^\circ\text{C}$)	-20 to +70

SOLDER COVERED BY SONY ADHESIVE

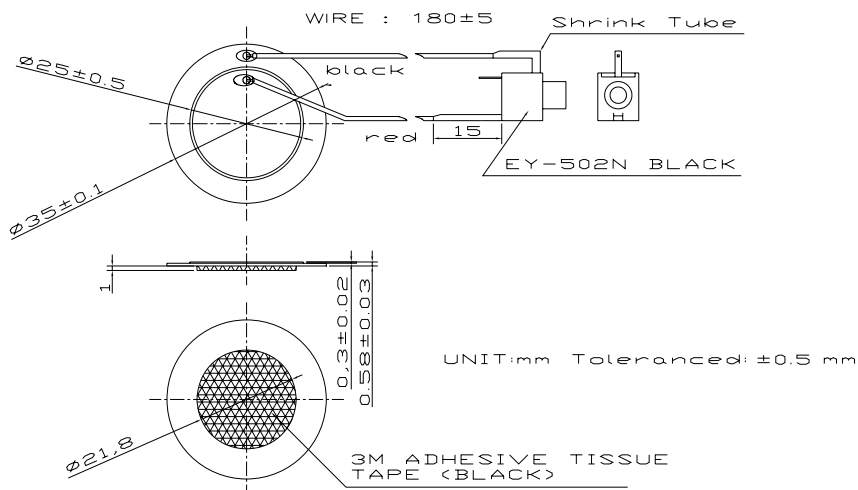

■ Piezo Ceramic Test Fixture

1. Resonant Freq. → YHP – 4192A at 1 Vrms (sweep frequency : 1KHz)
2. Resonant Imp. → YHP – 4192A at 1 Vrms (sweep frequency : 1KHz)
3. Capacitance → YHP – 4192A at 1 KHz

■ Piezo Ceramic Reliability Test

No.	Item	Condition	Variance after Conditioning
01	High temperature	+70°C±2°C , 240 hrs	Resonant freq.: Initial value ±10%
02	Low temperature	-40°C±2°C , 240 hrs	
03	Humidity	+40°C±2°C , 90~95%RH , 240 hrs	
04	Thermal shock	-20°C±2°C (30min) →20°C (15min) →70°C±2°C (30min) →20°C (15min) 20 cycles	Capacitance: Initial value ±15%
05	Temp. dependence	On place -20~ +70°C rel. 20°C	Resonant freq.: ±15% Capacitance: 0.8% / °C

Test specimens shall be kept for 4 hrs. (25°C) before measurement.