SPECIFICATION FOR APPROVAL

Product	DYNAMIC RECEIVER
Part No.	AR-1537D32-17W
Customer Approval	

Approved By	Checked By	Made By



A & B COMPONENTS

[HTTP://WWW.SPEAKER-TW.COM](http://www.speaker-tw.com)

AR-1537D32-17W

ITEMS.		SPECIFICATIONS
01	Type	Dynamic receiver unit
02	Dimension.	External diameter 15mm
03	Sensitivity (S.P.L)	114 dB \pm 3 dB at 1kHz 180mV with IEC 318 coupler
04	Frequency Response.	Refer to frequency response chart.
05	Impedance.	32 Ohm \pm 20% at 1KHz
06	Magnet Field Intensity.	Axial – dB , Radial –dB at 1KHz
07	Nominal Input Power	50mW
08	Max. Input Power.	Must be normal at a white noise , 100mW for 1 minute.
09	Weight.	2g \pm 0.2g
10	Appearance.	Should not exist any obstacle to be harmful to normal operation: damages, cracks, rusts, and distortions, etc.
11	Buzz, Rattle, Etc.	Should not be audible at 1.26V sine wave between 300 Hz to 3.4 kHz.
12	Terminal Strength.	Capable of withstanding 1 kg load for 15 sec without resulting in any damage or rejection.
13	Load Test.	1.26V white noise (-filter) is applied for 72 hours satisfy the tests listed on item 03,04,09, and10

ENVIRONMENTAL TEST.

Sensitivity difference shall be within \pm 3 dB and should satisfy the listed on item03,04, 09 and 10, after each following test.

01	Thermal Cycle Test.	Low temperature: -40°C \pm 3°C, temperature:+70°C \pm 3°C, cycle: 6hour/cycles each, and then keep 2 hours in a room.
02	High Temp. Test.	Keep 96 hours at +70°C \pm 3°C and leave 6 hours in normal temperature and then check.
03	Low Temp. Test.	Keep 96 hours at -40°C \pm 3°C and leave 6 hours in normal temperature and then check.
04	Humidity Test	Keep 96 hours at +40°C \pm 3°C and relative humidity 95% and leave 3 hours in normal temperature and then check.
05	Drop Test	Drop the handset mounted a unit onto a board 5mm thick 18 times from the height of 1m and them should satisfy the test listed on item 09 and 10.

MEASUREMENT CONDITION.

Test and measurement will be carried out under normal condition of temperature within 5°C to 35°C, Relative humidity within 45% to 85% and air pressure of 860mbar to 1060mbar.

Should uncertainly arise in data obtained from the above atmosphere, control of temperature at 20°C ±2°C and relative humidity within 60% and 70%, With air pressure remaining unchanged, to be enforced.

1. Test signal. :180mV
2. Sweep freq. Response. :Apply test signal varying logarithmical from 100Hz to 10kHz, 2 times for 0.5 second.
3. S.P.L (Sensitivity). :Read out average figure of S.P.L meter needle.
4. Freq. response curve. :Apply test signal and check response curve with frequency response recorder.

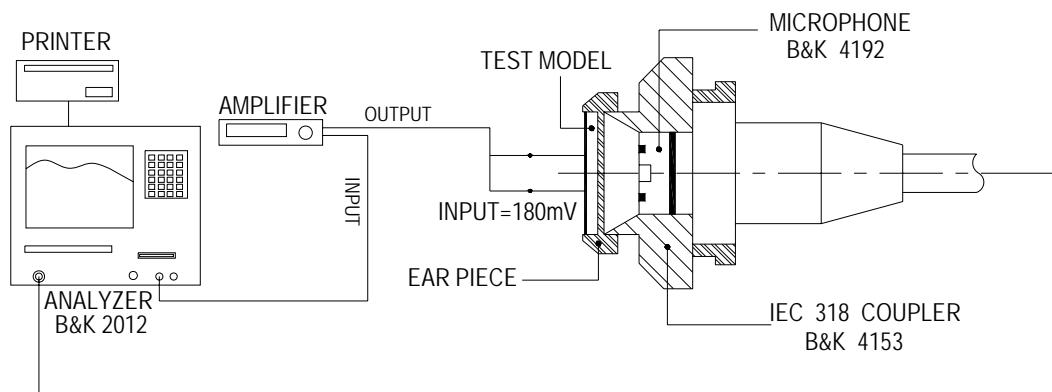

FREQUENCY RESPONSE CURVE

X:1.0054kHz Y:114.18dB ZA:Live Curve TSR fund.



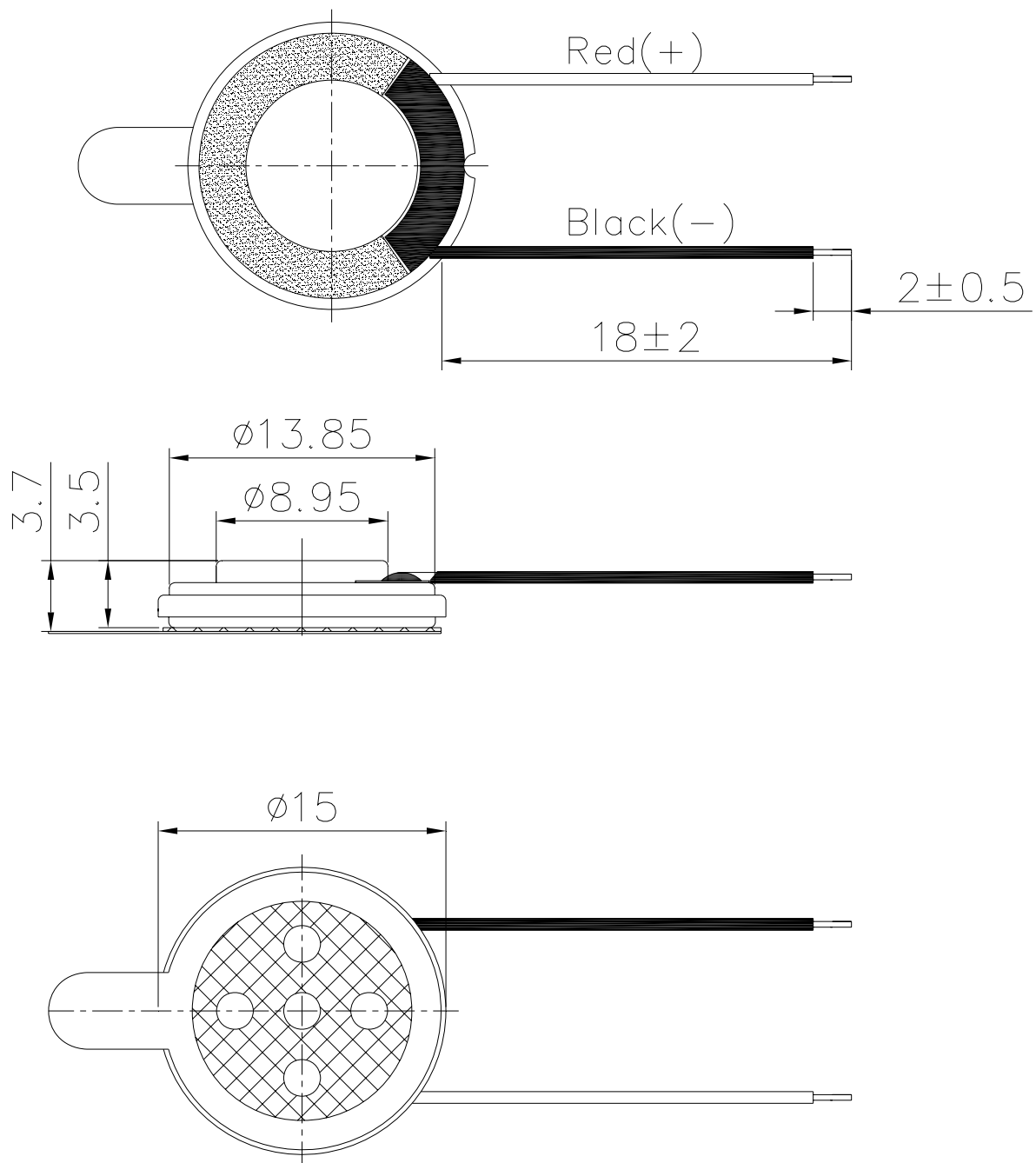

NOTES:
WIRES: UL1571 32#AWG

TITLE: MULTI FUNCTION SPEAKER		DRAWN: <i>Richard</i> 2004/06/17	SCALE: 2:1	SHEET: 1 of 1
PART NO. AR-1537D32-17W	1	DESIGNED: R & D DEP.	UNITS: mm	
DWG NO. DRE-1008		CHECKED:	TOLERANCE ± 0.2	
REV		APPROVAL:	UNLESS OTHERWISE SPECIFIED: ONE PLACE DECIMAL \pm *** TWO PLACE DECIMAL \pm *** THREE PLACE DECIMAL \pm ***	
		MATERIAL: Iron		

A & B Components