SPECIFICATION FOR APPROVAL

| | |
|-------------------|-----------------|
| Product | DYNAMIC SPEAKER |
| Part No. | AS-1540M08-A1T |
| Customer Approval | |

| Approved By | Checked By | Made By |
|-------------|------------|---------|
| | | |



A & B Components

<http://www.speaker-tw.com>

AS-1540M08-A1T

| | | | |
|----|--------------------------|---|-------------------------------|
| 01 | Type | Dynamic speaker | |
| 02 | Dimension | External diameter 15 mm | |
| 03 | Rated Input Power | 0.3 W | |
| 04 | Impedance | 8 ohm \pm 15% at 800Hz | |
| 05 | Resonance Frequency (Fo) | 800 Hz \pm 20% at Fo, 1V | |
| 06 | Sensitivity (S.P.L.) | 74dB(W/m) \pm 3 dB | at AVE 0.8K,1K,1.2K,1.5K(Hz). |
| | | 88dB(0.3W/0.1m) \pm 3 dB | |
| 07 | Frequency Range | Fo – 5KHz | |
| 08 | Distortion | Less than 10 % at 1KHz 0.3 W | |
| 09 | Max. Input Power | Must be normal at 0.5W white noise for 1 minute. | |
| 10 | Voice Coil | Diameter Φ 8.35 mm | |
| 11 | Magnet | Rare earth permanent (ND) magnet Φ 7.5x1.3mm | |
| 12 | Weight | 1.43g \pm 0.3g | |
| 13 | Appearance | Should not exist any obstacle to be harmful to normal operation; damages, cracks, rusts and distortions, etc. | |
| 14 | Operation Test | Must be normal at program source 0.3W | |
| 15 | Buzz, Rattle, etc. | Should not be audible at 0.89V sine Wave between Fo to 20KHz | |
| 16 | Polarity | When positive voltage is applied to the terminal marked (+), diaphragm should move to the front. | |
| 17 | Terminal Strength | Capable of withstand 1kg load for 30 seconds without resulting in any damage or rejection. | |
| 18 | Load Test | 0.3 W white noise is applied for 96 hours and satisfy the test listed on item 05,06,13,15 | |
| 19 | High Temp. Test | Keep 96 hours at +70°C \pm 3°C and leave 3 hours in normal temperature and then check | |
| 20 | Low Temp. Test | Keep 96 hours at -20°C \pm 3°C and leave 3 hours in normal temperature and then check | |
| 21 | Humidity Test | Keep 96 hours at + 60°C \pm 3°C relative humidity 95% and leave 3 hours in normal temperature and then checked. | |
| 22 | Drop Test | Drop the speakers contained in normal box onto the board 20mm thick 10 times from the height of 0.75m and then should satisfy the test listed on item 13 and 15 | |

Measurement Condition

Test and measurement will be carried out under normal condition of temperature

within 5°C to 35°C , relative humidity within 45% to 85% and air pressure of 860mbar to 1060mbar.

Should uncertainly arise in data obtained from the above atmosphere, control of temperature

At $20^{\circ}\text{C} \pm 2^{\circ}\text{C}$ and relative humidity within 60% and 70%, with air pressure remaining unchanged,

To be enforced.

1. Microphone : B&K 4191

2. Standard Baffle : In IEC 268-5 Where 1350mm x 1650mm

3. Testing Distance : 0.1m

4. Zero Level : -dB

5. Mode : SPEAKER

6. Input Power : 0.3W

7. potentiometer Range : 50dB

8. Sweep Time : 0.5sec

Standard test condition of speaker

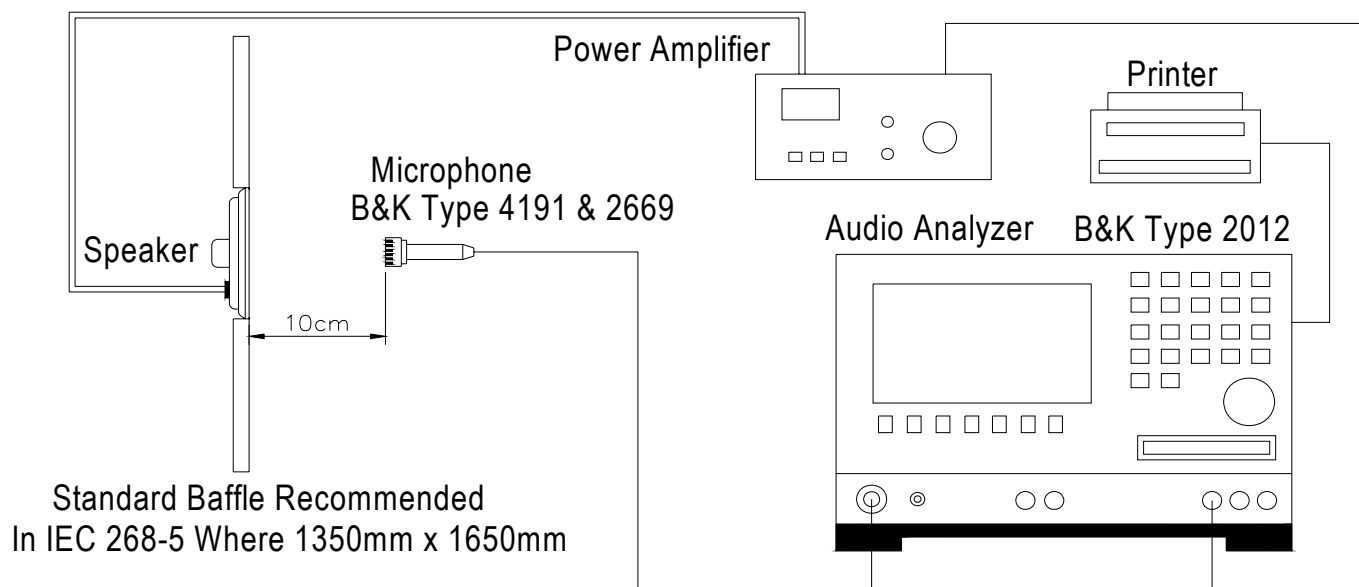

Frequency Response Curve

AK-1508MA-1

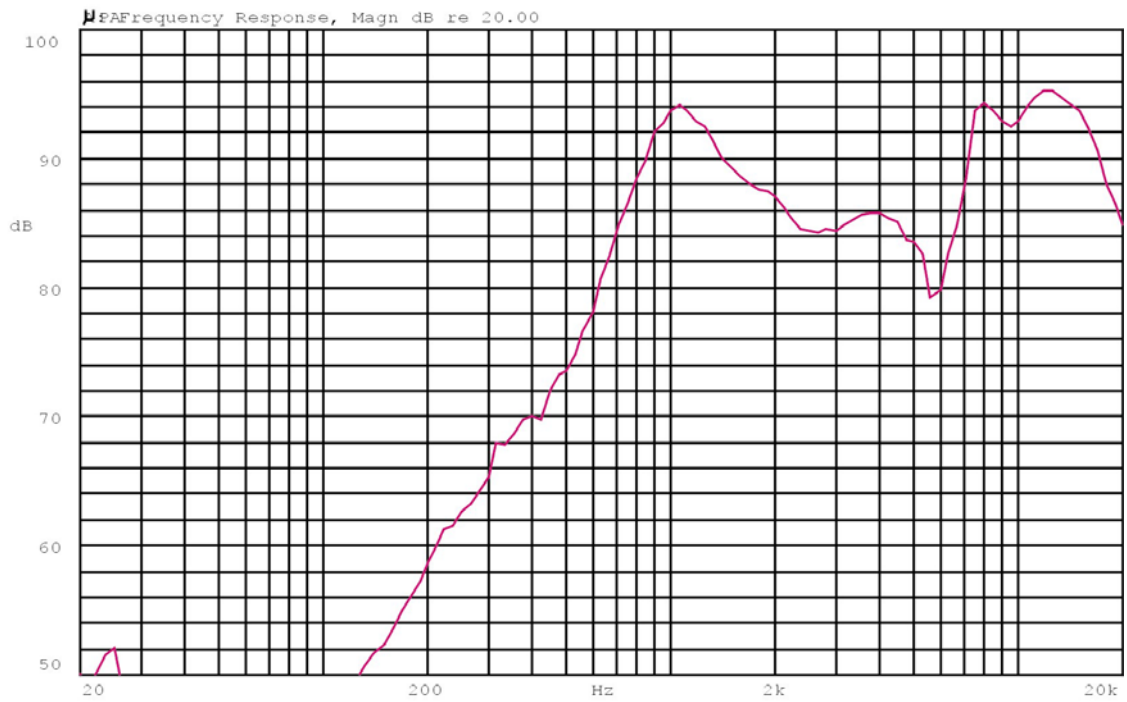

Mode: SPEAKER



Impedance Curve

IMPEDANCE MEASUREMENTS: Measurement of Impedance [1]

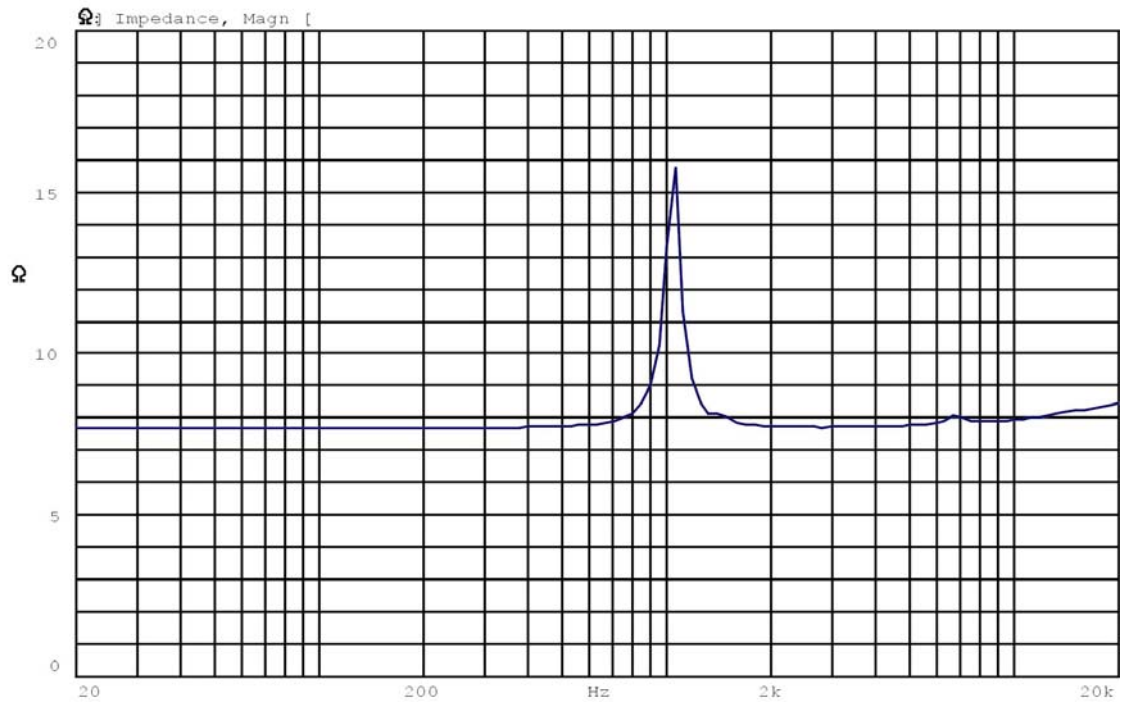

Mode: Z(jw)



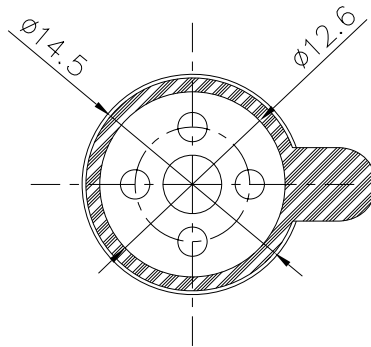
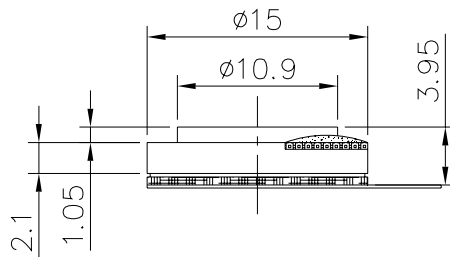
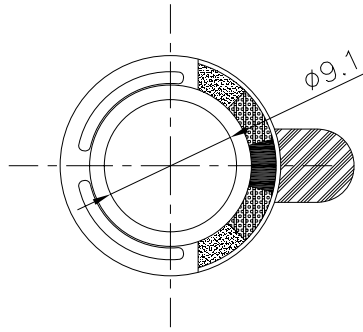

| | | | | |
|--------------------------------|--|----------------------------------|-----------------------------|---------------|
| TITLE: <i>DYNAMIC SPEAKER</i> | | DRAWN: <i>Richard</i> 01/29/2003 | SCALE: 2:1 | SHEET: 1 of 1 |
| PART NO. <i>AS-1540M08-A1T</i> | | DESIGNED: <i>R&D DEP.</i> | UNITS: <i>mm</i> | |
| DWG NO. <i>DTS-1379</i> | | CHECKED: | TOLERANCE ± 0.2 | |
| | | APPROVAL: | UNLESS OTHERWISE SPECIFIED: | |
| REV <i>1</i> | | MATERIAL: <i>*****</i> | ONE PLACE DECIMAL ± *** | |
| | | | TWO PLACE DECIMAL ± *** | |
| | | | THREE PLACE DECIMAL ± *** | |

A & B Components