SPECIFICATION FOR APPROVAL

Product	DYNAMIC SPEAKER
Part No.	AS-1738D16-B1T
Customer Approval	

Approved By	Checked By	Made By



A & B Components

<http://www.speaker-tw.com>

AS-1738D16-B1T

01	Type	Dynamic speaker	
02	Dimension	External diameter 17 mm	
03	Rated Input Power	0.5 W	
04	Impedance	16 ohm \pm 15% at 2K Hz	
05	Resonance Frequency (Fo)	850 Hz \pm 20% at Fo, 1V	
06	Sensitivity (S.P.L.)	75dB(W/m) \pm 3 dB	at AVE 0.8K,1K,1.2K,1.5K(Hz).
		91dB(0.5W/0.1m) \pm 3 dB	
07	Frequency Range	Fo – 20KHz	
08	Distortion	Less than 10 % at 1KHz 0.5 W	
09	Max. Input Power	Must be normal at 1.0W white noise for 1 minute.	
10	Voice Coil	Diameter 7.4 mm	
11	Magnet	Rare earth permanent (Nd-Fe-B) magnet Φ 6.5x1.2mm	
12	Weight	1.6g \pm 0.3g	
13	Appearance	Should not exist any obstacle to be harmful to normal operation; damages, cracks, rusts and distortions, etc.	
14	Operation Test	Must be normal at program source –0.5W	
15	Buzz, Rattle, etc.	Should not be audible at 2.83V sine Wave between Fo to 20KHz	
16	Polarity	When positive voltage is applied to the terminal marked (+), diaphragm should move to the front.	
17	Terminal Strength	Capable of withstand 1kg load for 30 seconds without resulting in any damage or rejection.	
18	Load Test	0.5 W white noise is applied for 96 hours and satisfy the test listed on item 05,06,13,15	
19	High Temp. Test	Keep 96 hours at +70°C \pm 3°C and leave 3 hours in normal temperature and then check	
20	Low Temp. Test	Keep 96 hours at -20°C \pm 3°C and leave 3 hours in normal temperature and then check	
21	Humidity Test	Keep 96 hours at + 60°C \pm 3°C relative humidity 95% and leave 3 hours in normal temperature and then checked.	
22	Drop Test	Drop the speakers contained in normal box onto the board 20mm thick 10 times from the height of 0.75m and then should satisfy the test listed on item 13 and 15	

Measurement Condition

STANDARD

Temperature : 5 ~ 35°C

Relative humidity : 45% ~ 85%,

Atmospheric pressure : 860mbar to 1060mbar.

JUDGEMENT

Temperature : 20±3°C

Relative humidity : 60% ~ 70%,

Atmospheric pressure : 860mbar to 1060mbar

1. Microphone : B&K 4191

2. Standard Baffle : In IEC 268-5 Where 1350mm x 1650mm

3. Testing Distance : 0.1m

4. Zero Level : -dB

5. Mode : SPEAKER

6. Input Power : 0.5W

7. potentiometer Range : 50dB

8. Sweep Time : 0.5sec

Standard test condition of speaker

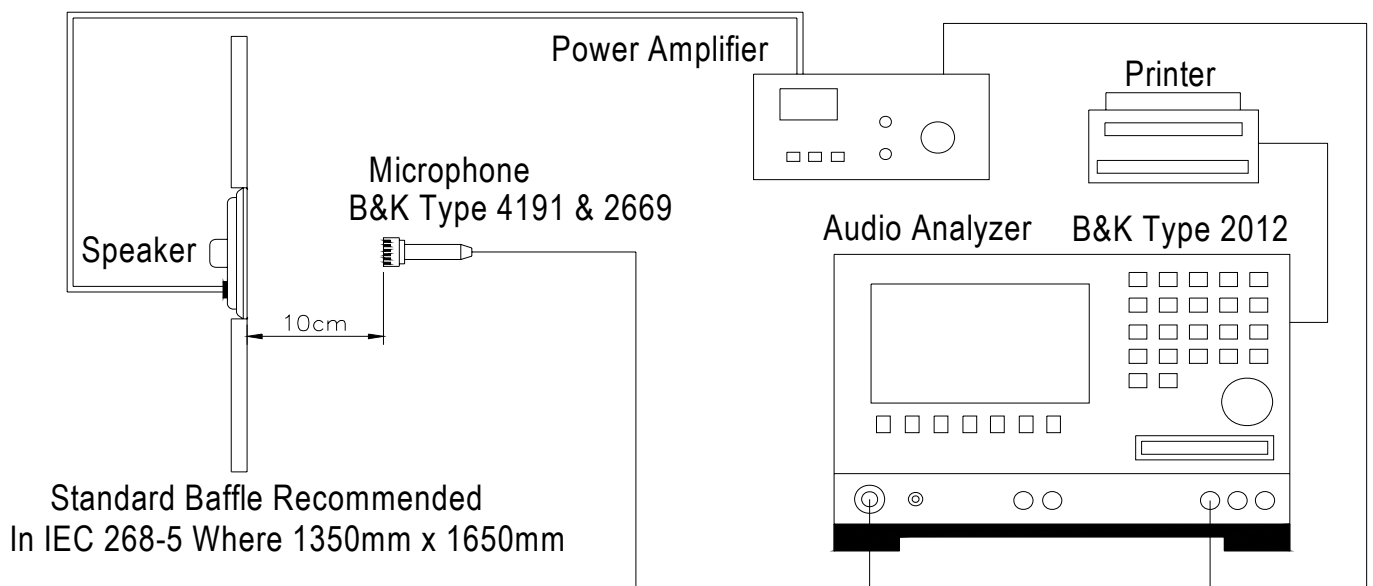

Frequency Response Curve

AK-1716DA-1

X:800.00Hz

*Y:90.83dB

ZA:Live Curve

SSR Fund.

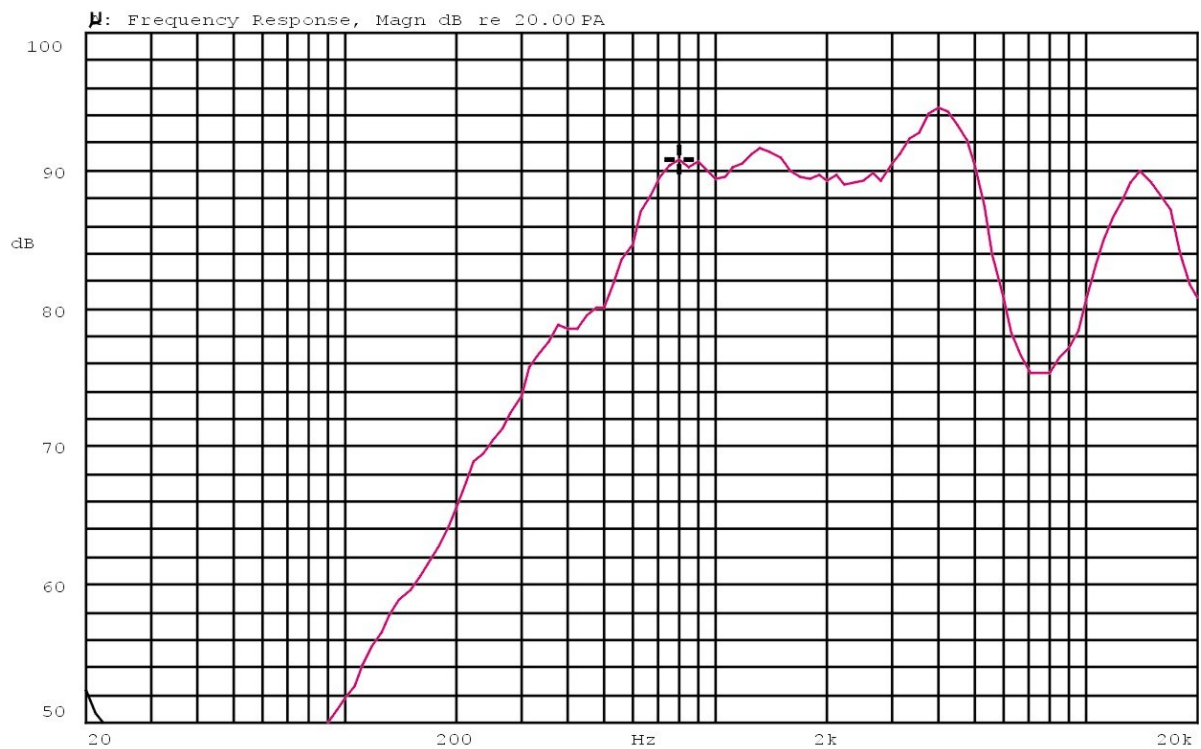

Mode: SPEAKER



Impedance Curve

IMPEDANCE MEASUREMENTS: Measurement of Impedance $Z(j\omega)$

ZA:Live Curve Impedance

X:2.0000kHz Y:15.31 Ω

Ω: Impedance, Magn [

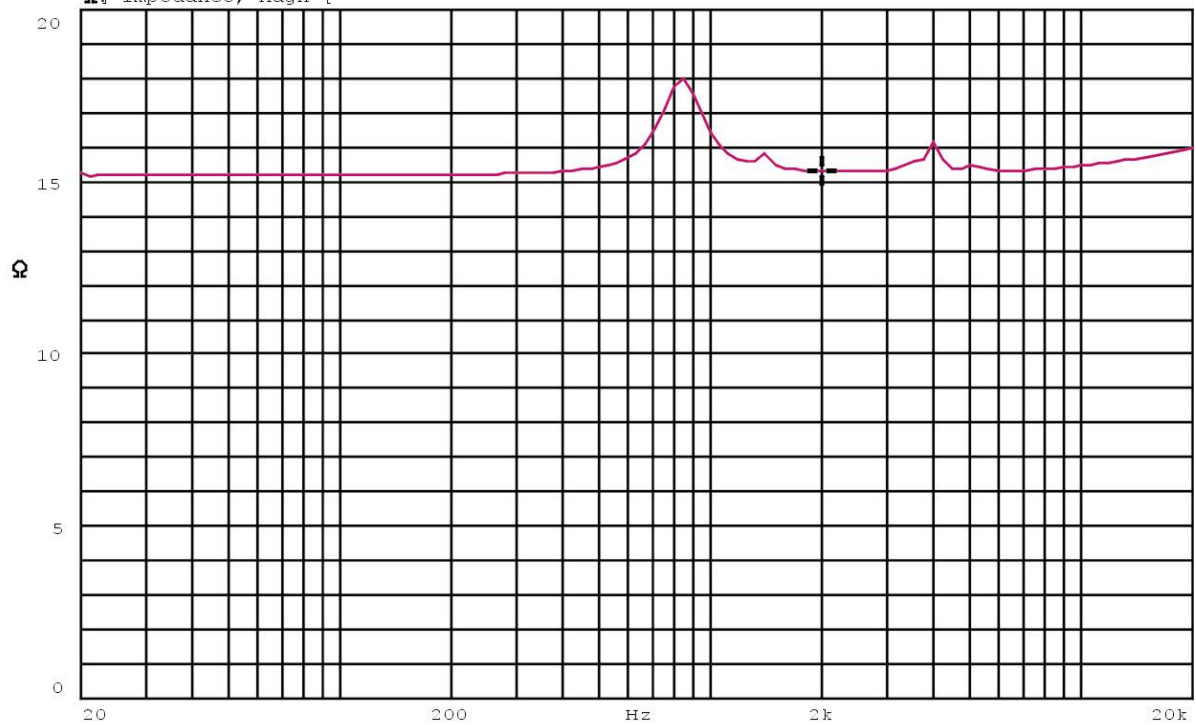

Mode: $Z(j\omega)$



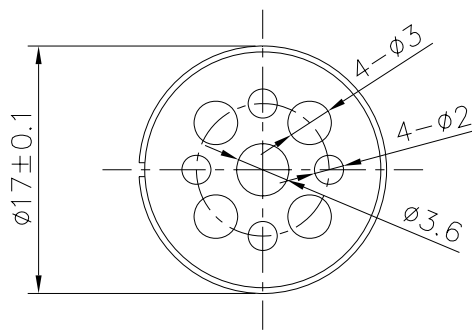
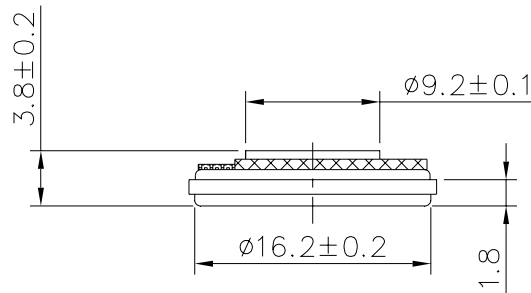
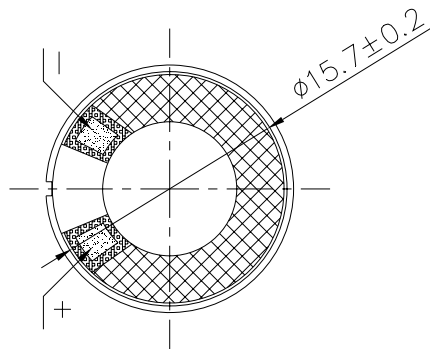

TITLE: <i>DYNAMIC SPEAKER</i>		DRAWN: <i>Richard</i> 06/18/2004	SCALE: 2:1	SHEET: 1 of 1
PART NO. <i>AS-1738D16-B1T</i>		DESIGNED: R&D DEP.	UNITS: mm	
DWG NO. <i>DTS-1395</i>	1 REV	CHECKED:	TOLERANCE ± 0.2	
		APPROVAL:	UNLESS OTHERWISE SPECIFIED: ONE PLACE DECIMAL \pm *** TWO PLACE DECIMAL \pm *** THREE PLACE DECIMAL \pm ***	
		MATERIAL: *****		

A & B Components