

---

# SPECIFICATION FOR APPROVAL

Product	PIEZO BUZZER
Part No.	AZ-2455E-W
Customer Approval	

Approved By	Checked By	Made By



**A & B Components**

**<http://www.speaker-tw.com>**

# AZ-2455E-W

Items	Units	Specifications	Conditions	
01	Rated Voltage	Vp-p	15	Square Wave
02	Operating Voltage	Vp-p	1-30	
03	Rated Current (Max)	mA	13	
04	Min Sound Output	dB	90	at 5.5Kz / 10cm
05	Resonant Frequency	Hz	5500±700	
06	Operating Temp.	°C	-20 ~ +70	
07	Storage Temp.	°C	-30 ~ +80	
08	Capacitance at 120 Hz	pF	18000 ± 30%	
09	Weight	g	1.9	

## Frequency Response Curve

MODEL:AZ-2455E-W  
 X:5.4639kHz Y:102.38dB ZA:Live Curve SSR T. RMS

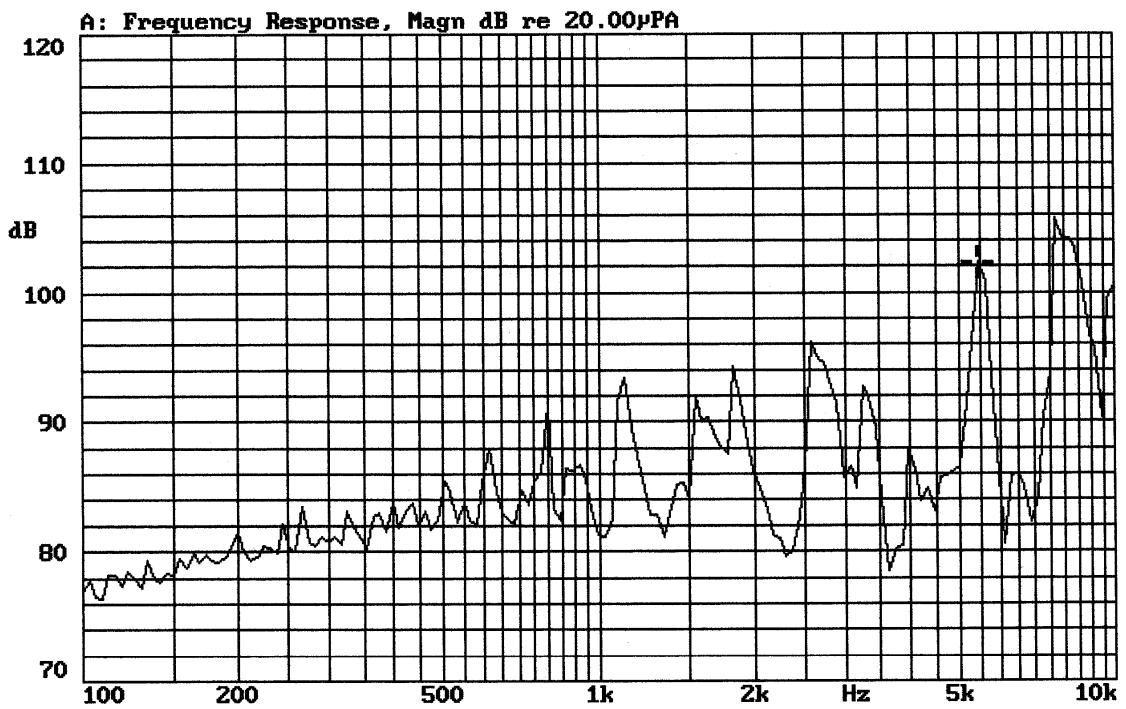

Mode: SSR



REV NO.	REVISION NOTE	APPROVAL	DATE
---------	---------------	----------	------

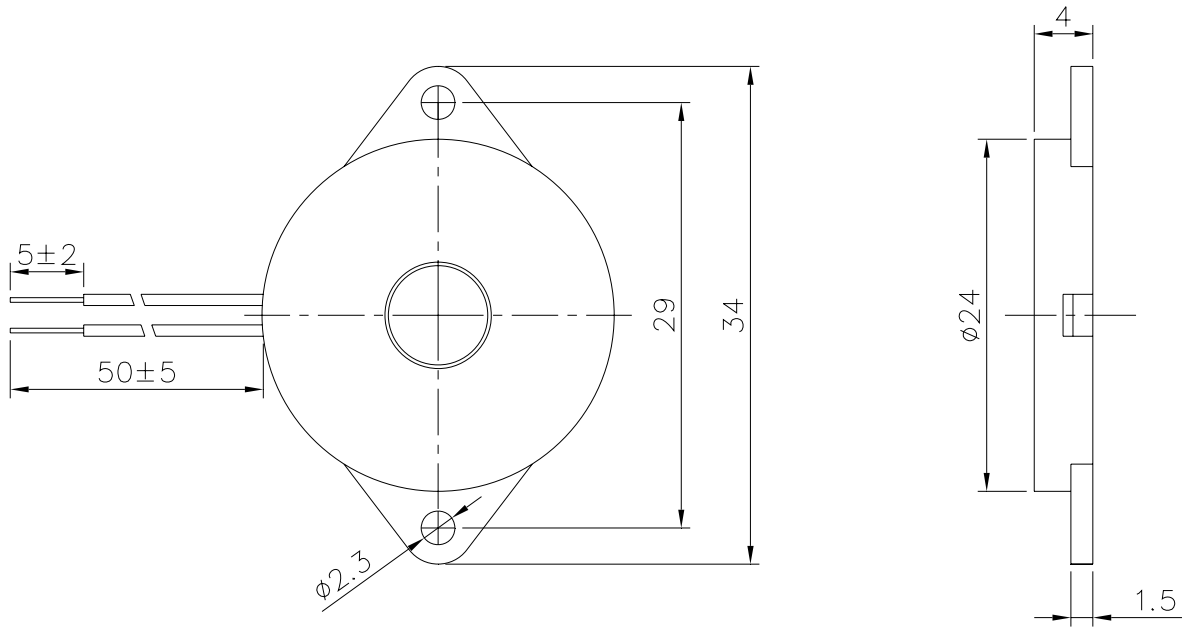

lead wire/lead pin material:UL1571 AWG32

TITLE: <i>PIEZO BUZZER</i>		DRAWN: <i>Richard</i> 04/26/2001	SCALE: 2:1	SHEET: 1 : 1
PART NO. <i>AZ-2455E-W</i>	1	DESIGNED: R & D DEP.	UNITS: mm	
DWG NO. <i>DTP-1023</i>		CHECKED:	TOLERANCE $\pm 0.5$	
	REV	APPROVAL:	UNLESS OTHERWISE SPECIFIED:	
		MATERIAL: ABS	ONE PLACE DECIMAL $\pm$ ***	
			TWO PLACE DECIMAL $\pm$ ***	
			THREE PLACE DECIMAL $\pm$ ***	

*A & B Components*

# RELIABILITY TEST

## AZ-2455E-W

Item		Conditions	Evaluation standard
01	Low Temp. Storage Test	A°C±2°C ,240Hr	(S.P.L)Test before numerical ±10dB *wrong (Frequency)Test before numerical ±10% (Current)Test before numerical ±10% (No crake is allowed on the part surface after Free drop test ) ● After the test ,the part shall meet the specifications without any degradation in appearance and performance
02	High Temp.Storage Test	B°C±2°C RH50% ,240Hr	
03	Temp./Humidity Storage Test	40°C±2°C , RH90-95% 240Hr	
04	Thermal Shock Test	A°C±2°C (1Hr)→ ,20°C±2°C (1Hr) B°C±2°C (1Hr)→ ,20°C±2°C (1Hr)10 cycle	
05	Vibration Test	10-55Hz/1min amplitude1.5mm,X,Y,Z,3 directions	
06	Mechanical Shock Test	+100G,Sine wave, XYZ , 3 impacts per axis	
07	Free Drop Test	The part shall be dropped freely from a height of 75 cm onto concrete 1 time in 2 axes (total 4 times )	
08	Life Burning Test	The part shall be subjected to 1000 hrs in the room temp with rated voltage applied	
09	Lead Wire / Pin Pull Test	The Part checking standard : Following supplier's Spec. Finished-part checking Standard vertical Pull i)100g MIN 0.05mm Thickness of ceramic ii)300g MIN 0.1mm ≤ Thickness of ceramic b: Horizontal Pull i)700g MIN	

Remark : "A"means Storage low temp. "B"means Storage high temp