SPECIFICATION FOR APPROVAL

Product	PIEZO BUZZER ELEMENT
Part No.	AE-5014E-W
Customer Approval	

Approved By	Checked By	Made By



A & B Components

<http://www.speaker-tw.com>

AE-5014E-W

ITEM		CONDITION
01	Type.	External -drive type sound element
02	Rated Voltage (Square Wave)	10 Vp-p
03	Operating Voltage	1 -25 Vp-p
04	Resonant Frequency (KHz)	1.4± 0.5 at 25± 2°C , 45~60% RH
05	Min Sound Output at 1.4KHz	65dB at 10cm/10p-p Square Wave
06	Capacity (pF)	50000±30% at 120Hz
07	Operating Temperature (°C)	-20 ~ +60
08	Storage Temperature (°C)	-30 ~ +70
09	Weight	1.0g

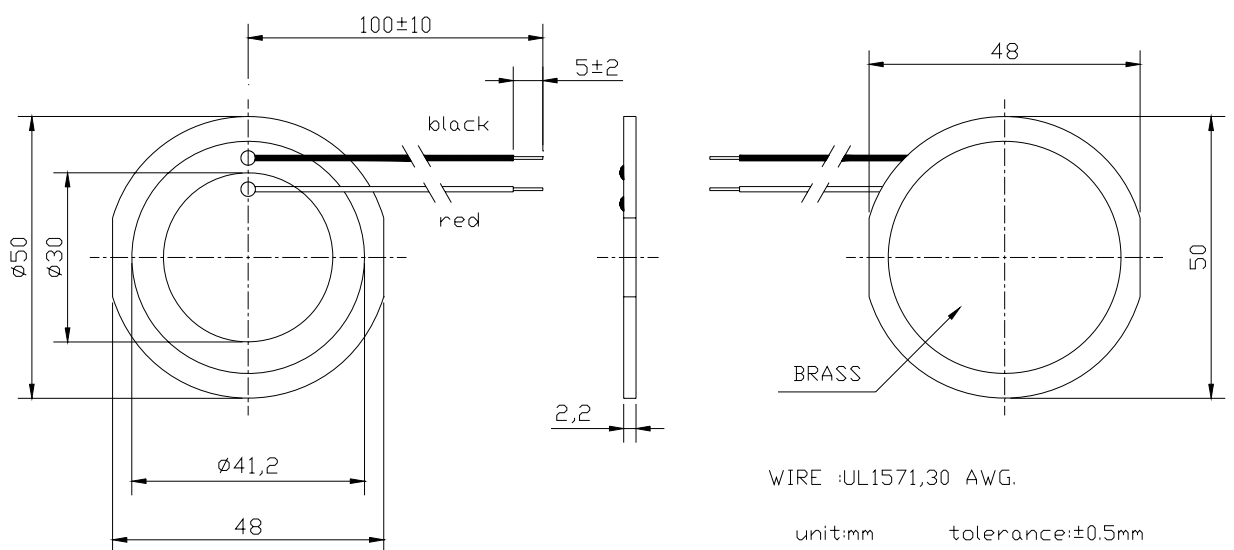

A2-5014B-W

X:1.4125KHz

Y:92.06dB

ZA:Live Curve

SSR T. RMS

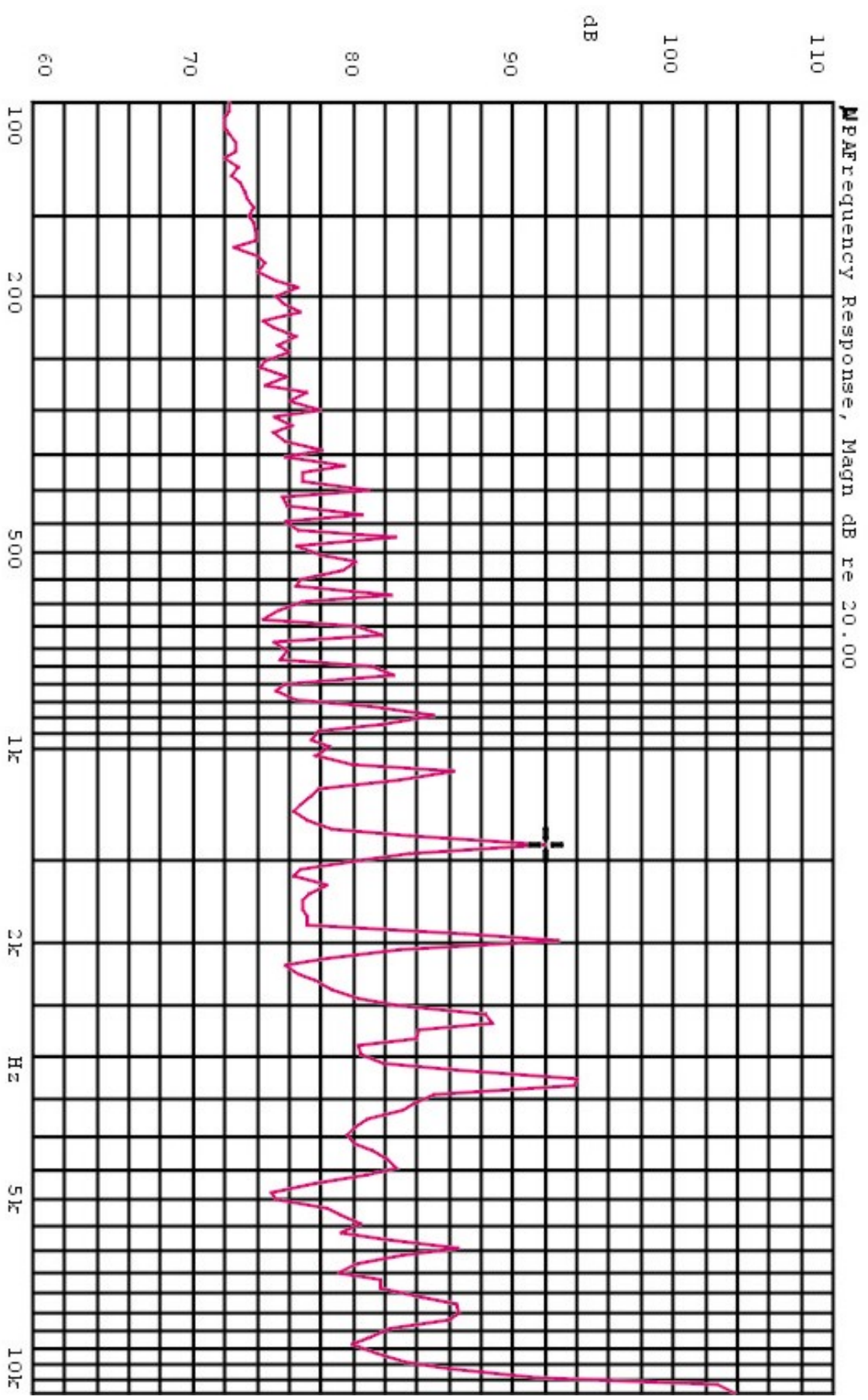

Mode: SSR



■ Piezo Ceramic Test Fixture

1. Resonant Freq. → YHP – 4192A at 1 Vrms (sweep frequency : 1KHz)
2. Resonant Imp. → YHP – 4192A at 1 Vrms (sweep frequency : 1KHz)
3. Capacitance → YHP – 4192A at 1 KHz

■ Piezo Ceramic Reliability Test

No.	Item	Condition	Variance after Conditioning
01	High temperature	+70°C±2°C , 240 hrs	Resonant freq.: Initial value ±10%
02	Low temperature	-40°C±2°C , 240 hrs	
03	Humidity	+40°C±2°C , 90~95%RH , 240 hrs	
04	Thermal shock	-30°C±2°C (30min) →20°C (15min) →70°C±2°C (30min) →20°C (15min) 20 cycles	Capacitance: Initial value ±15%
05	Temp. dependence	On place -20~ +70°C rel. 20°C	Resonant freq.: ±15% Capacitance: 0.8% / °C

Test specimens shall be kept for 4 hrs. (25°C) before measurement.